

FOR LEASE

3 STORY HIGH IMAGE OFFICE BUILDING

8141 E. Kaiser Blvd., Anaheim Hills, CA



PROPERTY FEATURES

- A 3-Story Office Building with approximately $\pm 37,987$ SF.
- The building was built utilizing “Class A” construction with high fire brick fascade and reflective bronze glass.
- The office building is located within walking distance to the Anaheim Hills Festival Shopping Center with over $\pm 600,000$ square feet of retail and restaurants.



MIKE BOOMER

Vice President

714.935.2344

Lic. #01209091

mboomer@voitco.com

Voit

REAL ESTATE SERVICES

2400 E. Katella Avenue, Suite 750, Anaheim, CA 92806

714.978.7800 • 714.978.9431 Fax www.VoitCo.com

Licensed as Real Estate Salespersons by the DRE. The information contained herein has been obtained from sources we deem reliable. While we have no reason to doubt its accuracy, we do not guarantee it. ©2024 Voit Real Estate Services, Inc. All Rights Reserved. License #01991785

FOR LEASE

3 STORY HIGH IMAGE OFFICE BUILDING

8141 E. Kaiser Blvd., Anaheim Hills, CA

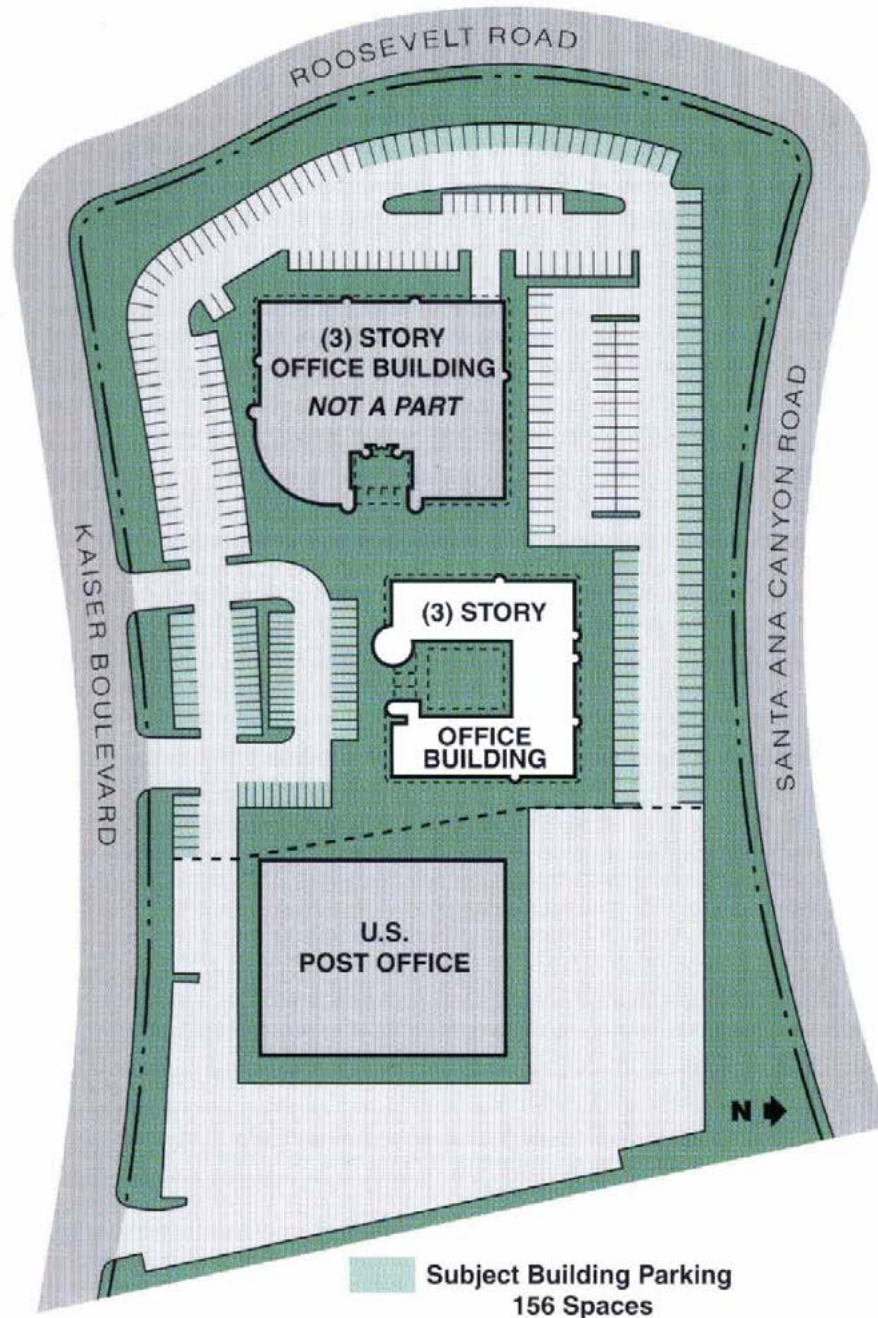

MIKE BOOMER
Vice President
714.935.2344
Lic. #01209091
mboomer@voitco.com

Voit
REAL ESTATE SERVICES

2400 E. Katella Avenue, Suite 750, Anaheim, CA 92806
714.978.7800 • 714.978.9431 Fax www.VoitCo.com

Licensed as Real Estate Salespersons by the DRE. The information contained herein has been obtained from sources we deem reliable. While we have no reason to doubt its accuracy, we do not guarantee it. ©2024 Voit Real Estate Services, Inc. All Rights Reserved. License #01991785

3 STORY HIGH IMAGE OFFICE BUILDING

8141 E. Kaiser Blvd., Anaheim Hills, CA

AVAILABILITY

Floor	Suite	Rentable Area SF	Lease Rate PSF	Comments
1	106	± 1,758	\$2.40 FSG	6 Private Offices, Available now
1	112	± 1,106	\$2.40 FSG	3 Private Offices

Lease Rate:	Full Service Gross
Expense Stop:	Base Year
Tenant Improvements:	Negotiable
Parking:	4:1,000
To Show Space:	Call Voit to set time to tour
Amenities:	Adjacent to Anaheim Hills Festival Center

As of 9/24/24

MIKE BOOMER
Vice President
714.935.2344
Lic. #01209091
mboomer@voitco.com

Voit
REAL ESTATE SERVICES

2400 E. Katella Avenue, Suite 750, Anaheim, CA 92806
714.978.7800 • 714.978.9431 Fax www.VoitCo.com

Licensed as Real Estate Salespersons by the DRE. The information contained herein has been obtained from sources we deem reliable. While we have no reason to doubt its accuracy, we do not guarantee it. ©2024 Voit Real Estate Services, Inc. All Rights Reserved. License #01991785

8141 E. KAISER BLVD., ANAHEIM HILLS

Suite 106 - ±1,758 SF

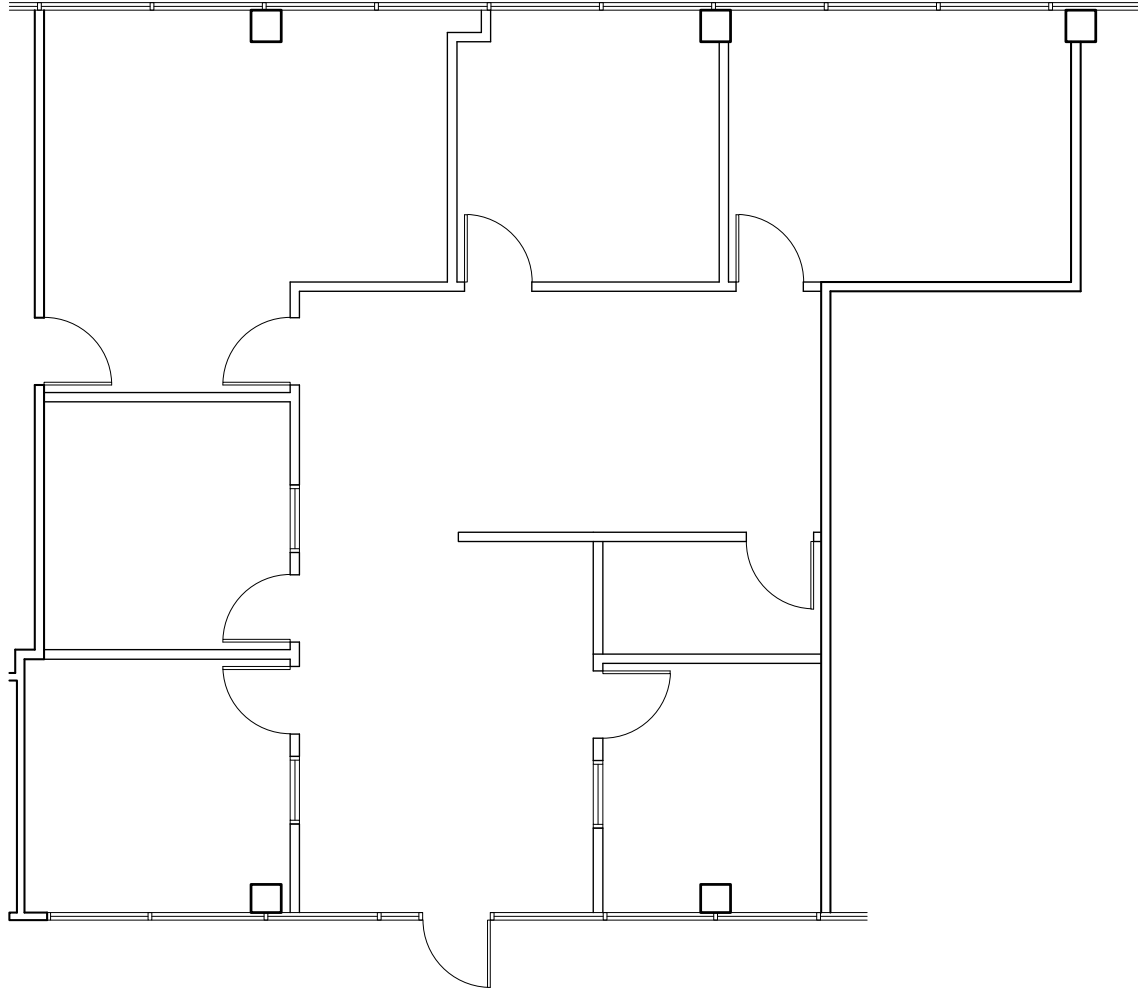

MIKE BOOMER
Vice President
714.935.2344
Lic. #01209091
mboomer@voitco.com

Voit
REAL ESTATE SERVICES

2400 E. Katella Avenue, Suite 750, Anaheim, CA 92806
714.978.7800 • 714.978.9431 Fax www.VoitCo.com

Licensed as Real Estate Salespersons by the DRE. The information contained herein has been obtained from sources we deem reliable. While we have no reason to doubt its accuracy, we do not guarantee it. ©2024 Voit Real Estate Services, Inc. All Rights Reserved. License #01991785

8141 E. KAISER BLVD., ANAHEIM HILLS

Suite 112 - ±1,106 SF

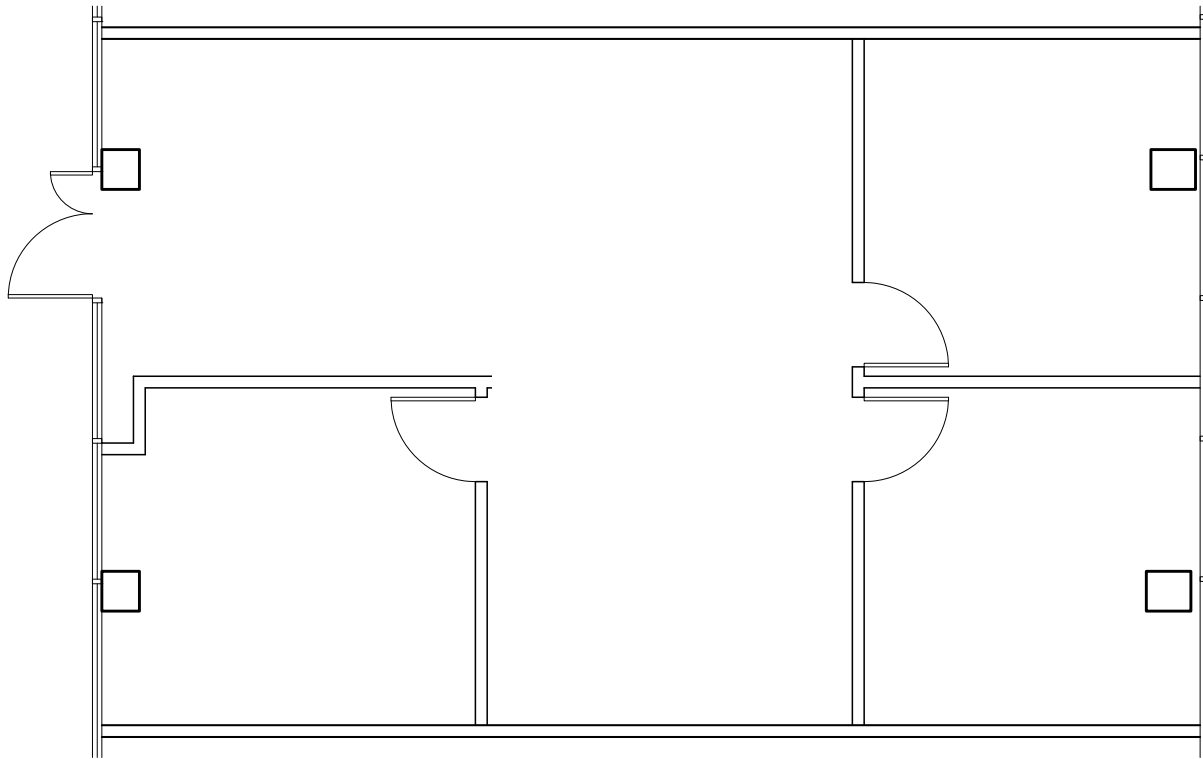

MIKE BOOMER
Vice President
714.935.2344
Lic. #01209091
mboomer@voitco.com

Voit
REAL ESTATE SERVICES

2400 E. Katella Avenue, Suite 750, Anaheim, CA 92806
714.978.7800 • 714.978.9431 Fax www.VoitCo.com

Licensed as Real Estate Salespersons by the DRE. The information contained herein has been obtained from sources we deem reliable. While we have no reason to doubt its accuracy, we do not guarantee it. ©2024 Voit Real Estate Services, Inc. All Rights Reserved. License #01991785